

Spectral Encoding and Decoding of Monolithic InP OCDMA Encoder

Jing Cao¹, R. G. Broeke¹, C. Ji¹, Y. Du¹, N. Chubun¹, P. Bjeletich¹, T. Tekin¹, P. L. Stephan², F. Olsson³, S. Lourdudoss³, and S. J. B. Yoo¹

1: Department of Electrical and Computer Engineering, University of California, Davis, CA 95616, U.S.A. yoo@ece.ucdavis.edu

2: Lawrence Livermore National Laboratory, U.S.A. 3: Royal Institute of Technology, Sweden

Abstract We report the optical-coding operation of monolithic, ultra-compact optical-CDMA encoder and decoder pair, consisting of InP based integrated AWGs and phase modulators. The encoder and decoder successfully demonstrate eight-bit Walsh code based encoding and decoding.

Introduction

The Optical Code Division Multiple Access (O-CDMA) technology is a promising approach for future all-optical access networks, thanks to its potentials for providing very flexible and high-capacity access to the vast networking capacity available [1]. While the feasibility of O-CDMA has been demonstrated in free space optical systems [2], monolithic chip-scale integration is required for reliable, low-cost, and large-scale commercial deployment of the O-CDMA technology [3]. The arrayed waveguide grating (AWG) is an attractive dispersive element as part of an O-CDMA spectral phase encoder or decoder, due to its integration compatibility in the InP based material system and its high spectral resolution. Previous work reported an AWG-based encoder using Si technology and a non-programmable external phase shifters [4]. This paper reports on the spectral encoding and decoding of 10 Gbit/s femtosecond pulses using fully-monolithic AWG-based O-CDMA encoder realized in an InP material system with planarized BH waveguides using Hydride Vapor Phase Epitaxy (HVPE) regrowth. The encoder incorporates an electro-optic phase shifter array for rapid code reconfigurations with negligible power consumption. This approach discussed previously [5] is suitable for future large-scale chip level integration for O-CDMA transmitters and receivers.

Principle

In a Spectral Phase Encoded Time Spreading (SPECTS)-OCDMA system O-CDMA encoder encodes the pulses by dividing the pulse spectrum into N spatially separated spectral components. Subsequently, the phase shifters apply 0 or π phase shift to each component before the encoder recombines these spectral components. The set of phase shifts for the N spectral components forms the O-CDMA code. The encoded pulse spreads out in the time domain with a corresponding reduction in the peak power. On the receiver side, a decoder (same configuration as the encoder but operating in reverse) decodes the encoded pulse. The decoder restores the phase conditions of the initial unencoded pulse and the original pulse shape only if the conjugate

code is used. Otherwise, the decoded pulse will also spread out in time.

Fig. 1 shows the packaged OCDMA encoder chip (top) and the chip layout (bottom). An ultra-short pulse enters AWG-1 and spatially separates into eight slices. An electro-optical phase shifter array then applies the O-CDMA code to the spectral slices, before AWG-2 routes the encoded pulse into a single output waveguide. The delay lines serve to equalize the optical path lengths of the spectral components passing through the AWG pair. The fabricated encoder chip was wire-bonded packaged in a butterfly package to allow programmable electrical access to the phase shifter arrays.

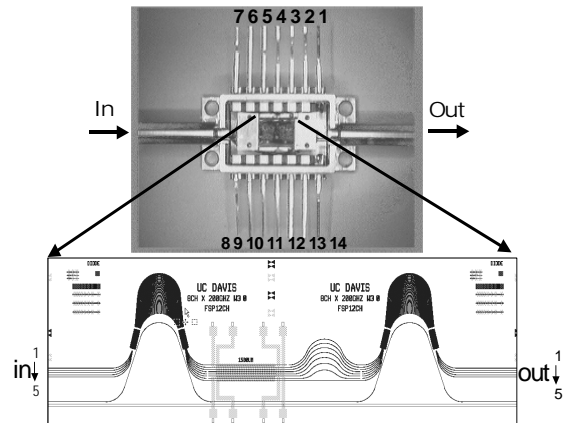

Fig.1. O-CDMA encoder package (top) and layout (bottom)

Experimental results

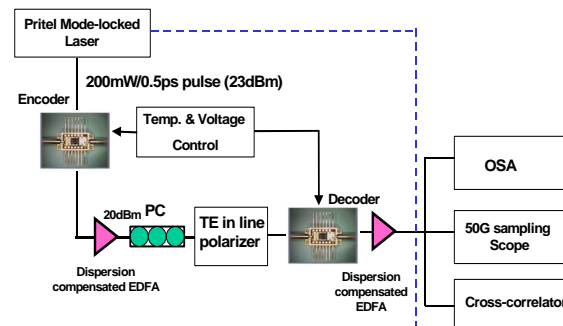

Fig.2. The experimental setup for spectral encoding and decoding

Fig. 2 shows the experimental setup for spectral encoding and decoding of the AWG based O-CDMA encoder and decoder chips. Two packaged encoder chips act as O-CDMA encoder and decoder respectively. The short pulse train with 10GHz repetition rate generated by a fiber mode-locked laser (Pritel) couples into the encoder. The encoded signal will be amplified by the first dispersion compensated Erbium-doped fiber amplifier (DC-EDFA) before entering the decoder. The decoded signal will be then amplified by a second DC-EDFA. The encoding and decoding operations are implemented by applying selected reverse bias voltage sequences across the electro-optic phase shifter array for both the encoder and decoder.

Fig. 3 shows the overlay optical spectra of the decoder and encoder chips. The encoder spectrum was shifted by 0.7nm through thermal tuning for exact overlap with the decoder spectrum and compensating for processing induced nonuniformity. A small contribution from the TM modes is present which will slightly degrade the coding performance.

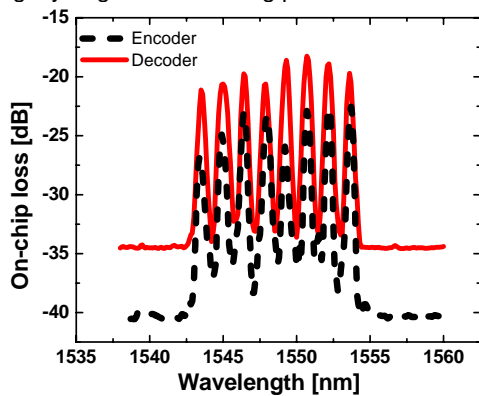

Fig.3. Measured transmission spectra of the encoder and decoder chips.

Fig. 4 shows the cross-correlation traces of the encoding/decoding operation under Walsh W5 code [11110000]. On the encoder side, Walsh W5 code was applied to the electro-optic phase shifter array, while on the decoder side different codes was applied to evaluate the encoder/decoder performance. Fig. 4(a) shows the correctly decoded signal when the conjugate code of W5 was applied to the decoder. The strong 5.6 ps period ringing peaks around the central main peak are due to the AWG spectral filtering response with 180 GHz channel spacing. Fig. 4(b) shows the incorrectly decoded case when the conjugate code of W7 was applied to the decoder (instead of the W5 conjugate), which did not properly decode the W5 encoded signal. For reference, Fig. 4(c) and Fig. 4(d) show the single stage encoder outputs under unencoded and W5 encoding conditions. In all four cases examined, the experimental and simulated results were all well matched. This shows that 8 channel OCDMA

encoder and decoder operations has been successfully demonstrated using the Walsh code.

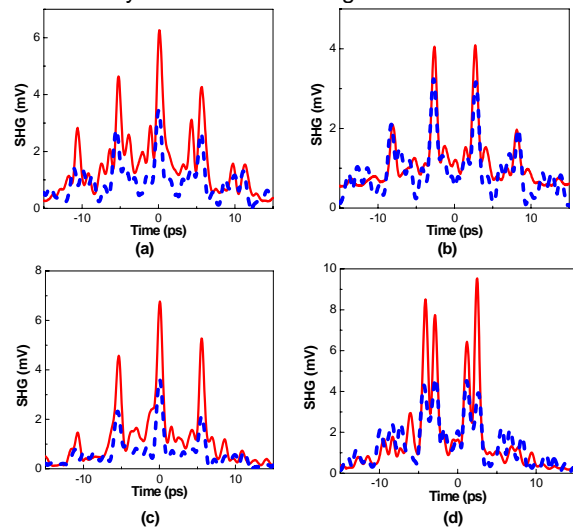

Fig.4. Cross-correlation traces of cascaded encoder-decoder output under W5 encoding and (a) correctly decoded, (b) incorrectly decoded conditions; and single stage encoder output under (c) unencoded (d) W5 encoding conditions.

(Solid lines are experimental results and dotted line are simulated result. W5 code is [11110000].)

Conclusions

We have successfully demonstrated Walsh Code encoding and decoding operations using a pair of monolithic eight-channel optical-CDMA encoder and decoder photonic chips in InP. The chips utilizes BH waveguides fabricated through a deep dry etching and a HVPE single step lateral re-growth process for sidewall passivation and surface planarization. The experimental results showed a reasonably good agreement with theoretical predictions, confirming that the encoder and decoder functioned as designed.

Acknowledgement

The authors thank K. Okamoto for enlightening discussions. This work was supported in part by DARPA/SPAWAR under agreement number N66001-02-1-8937, and by DARPA/ARO under agreement number W911NF-04-1-0066.

References

- 1 H. P. Sardesai, et al, J. Lightwave Technol., vol. 16 (1998), pp. 1953-64.
- 2 R. P. Scott, et al, IEEE Photon. Technol. Lett., vol. 16(2004), pp. 2186-88.
- 3 J. Cao, et al, OFC'2005, paper OFL6.
- 4 H. Tsuda, et al, IEE Electron. Lett., vol. 35(1999), pp.1186-8.
- 5 C. Ji, et al, IEEE J. Select. Topics Quantum Electron., vol. 1 (2005), pp. 66-77.